



CB15V

Heavy-Duty, One Gallon, Variable Speed Food Blender



*Made in USA with US and foreign parts.

ELECTRICAL

Voltage: 230

Frequency: 50/60Hz

Watts: 1800

Amps: 6.5

Plug Type: A

Cord Length: 6.6 feet



MAIN FEATURES



- Ultra-heavy-duty, 3.75 HP commercial motor — perfect for large loads and long blending times
- Variable-speed controls enable you to precisely adjust RPM speeds to perfectly control the consistency of your mixture
- Adjustable speeds from 1,700–18,000 RPM
- PULSE feature pulses at set speed to chop and mix
- Easy-to-clean, electronic-membrane keypad
- 1 gallon, stainless-steel container with two handles for carrying and pouring, and lid clamps for security
- Easy-off, rubberized lid with removable, clear cap for adding ingredients and for pressure reduction during hot food blending
- Durable, high-performance, stainless-steel blade
- Metal-on-metal, stainless-steel coupling system for durability and reliability
- Durable, full die-cast motor housing with rugged, rubber feet to reduce vibration
- Dishwasher-safe, one-piece jar pad for easy cleaning
- Recommended for 100+ drinks or servings per day
- Limited 3-Year Motor Warranty

SALES FEATURES

When it comes to ultra heavy-duty blenders, the Waring® CB15V has your back. Chop, mix and shred large loads that need long blending times with a powerful 3.75 HP motor—or make 100+ drinks per day. Variable speed controls allow you to precisely control the RPM, which means you can also tightly control the consistency of your signature recipes.



INCLUDED ACCESSORIES

-  **CAC77** Vinyl Lid for 1 Gallon Blender Jar
-  **CBL10** Hot Blending Lid for 1 Gallon Blenders
-  **CAC72** Two-Handle, 1 Gallon Stainless Steel Container with Blade Assembly and Lid

OPTIONAL ACCESSORIES

-  **CB15BU** Base Unit
-  **CAC125** Two-Handle, 1 Gallon Stainless Steel Container with Spigot, Blade Assembly and Lid
-  **CAC170** 1 Gallon, Stackable, 128 oz., BPA-Free Copolyester Container with Blade Assembly and Lid
-  **CAC32** 40 oz. Glass Container Complete with Blade Assembly and Lid (requires AD1)
-  **AD1** 1 Quart Adapter for 1 Gallon Blenders
-  **CAC19** 48 oz., BPA-Free Copolyester Container Complete with Blade Assembly and Lid (requires AD1)
-  **CAC33** 32-oz. Stainless Steel Container Complete with Blade Assembly and Lid (Requires AD1)
-  **CAC02** Outer Lid ONLY for 48 oz., BPA-Free Copolyester or 64 oz. Stainless Steel Container
-  **CAC04** Outer Lid ONLY for 32 oz. Stainless Steel Container
-  **CAC05** Center Lid ONLY for CAC01, CAC02, and CAC04

DIMENSIONS

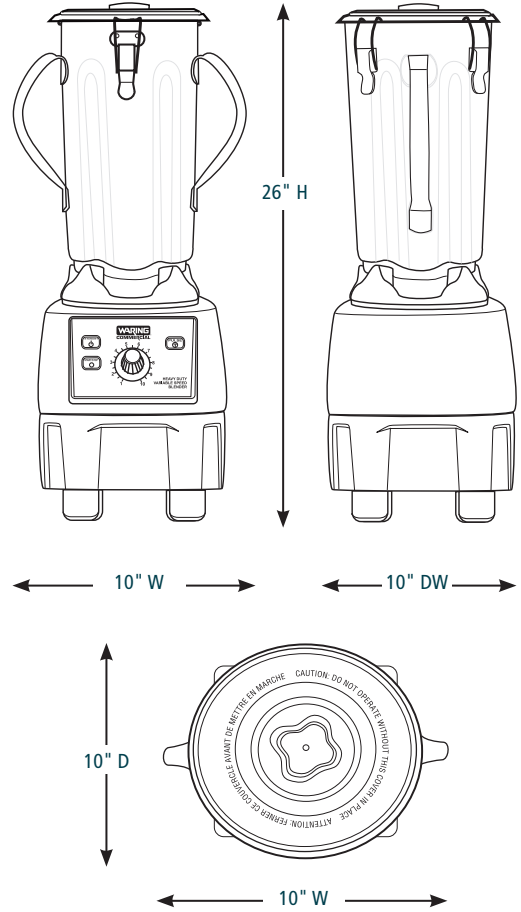

Out of Box Weight: 32.4 lb.

ORDERING INFORMATION	#STD. PKG.	GIFTBOX WEIGHT	CUBIC FEET	BOX DIMENSIONS L x W x H	UPC	CASE PKG.	MC WEIGHT	MC DIMENSIONS L x W x H	MBC
CB15V – One Gallon, Variable Speed Food Blender	1	38	2.9	22.125" x 15" x 15.25"	040072014468	1	38.6	22.125" x 15" x 15.25"	10040072014465



WolfLabs

Pricing on any accessories shown can be found by keying the part number into the search box on our website.

The specifications listed in this brochure are subject to change by the manufacturer and therefore cannot be guaranteed to be correct. If there are aspects of the specification that must be guaranteed, please provide these to our sales team so that details can be confirmed.

www.wolflabs.co.uk

Tel : 01759 301142

Fax : 01759 301143

sales@wolflabs.co.uk

Please contact us if this literature doesn't answer all your questions.